

DuraStar

Flat Glass LED Illuminator



The Most Dependable
LED Illuminator for all

RELIANCE®

Flat Glass Level Gages

- **High Contrast**
- **Superior Visibility Day or Night**
- **Field Upgradable**
- **Maintenance Free**
- **Long Life ~100,000 hrs.**
- **No Heat Generation**
- **Versatile
Continuous or "On-Demand"**
- **Amber LED's for high
intensity "star-like" image
of the water line**
- **Longest Field-of-View**
- **Pays for itself in electricity
savings alone!**
- **NO weather proof
illuminator hood used**



SPECIFICATIONS

Power Supply:	120 or 240 VAC @ 50-60 Hz
Power Consumption:	< 750 mA @120 VAC < 375 mA @ 240 VAC
Est. Life:	100,000 Hours (continuous)
Agency Approvals:	FM Approved, CSA Pending Class 1, Div I, Grps. B, C, & D Class II, Div I, Grps. E, F, & G
Wire Size:	Min 18 AWG / Max 12 AWG
Max Distance From Power Supply to Light Strip:	8 ft (2.5m)
Ambient Temperature:	-40 F (-40 C) to 170 F (77 C)
Electrical Connection:	½" FNPT



Clark-Reliance® is pleased to announce the addition of the DuraStar to the world's largest selection of level indication and control products for the boiler industry. The DuraStar is approved for use in Class 1, Div 1, Group B, C & D environments. Contact your local representative or a Reliance Applications Engineer to configure a DuraStar for your transparent glass level gages.

RELIANCE® *DuraStar* - Flat Glass Gage Illuminator

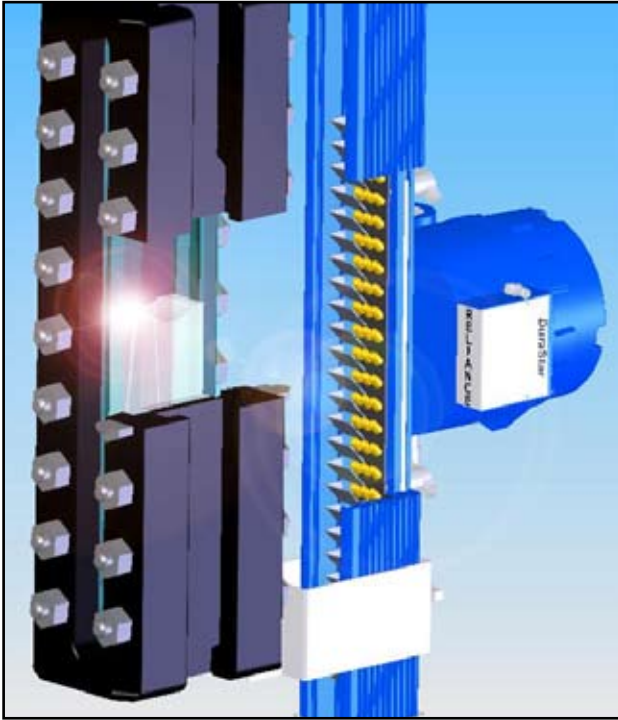

The DuraStar Illuminator uses three columns of “directed” amber color LED’s to create a brilliant star-like image at the water level. The DuraStar easily attaches to new or existing Reliance level gages without the use of tools.



**Explosion Proof Power Supply.
Intrinsically Safe Lighting Circuit.**

DuraStar Model No.	Fits Gage Glass	Length (Inches)	Length (mm)	Wt (LB)
DS1000-1411-1	FG404 or FG904	11.75	298	7.50
DS1000-1511-1	FG405 or FG905	13.00	330	7.75
DS1000-1611-1	FG406 or FG906	14.50	368	8.00
DS1000-1711-1	FG407 or FG907	15.75	400	8.25
DS1000-1811-1	FG408 or FG908	17.25	438	8.50
DS1000-1911-1	FG409 or FG909	18.00	457	8.75
DS1000-1411-2	FG1504 or FG2004	13.00	330	7.75
DS1000-1511-2	FG1505 or FG2005	14.50	368	8.00
DS1000-1611-2	FG1506 or FG2006	15.75	400	8.25
DS1000-1711-2	FG1507 or FG2007	16.50	419	8.50
DS1000-1811-2	FG1508	18.00	457	8.75
DS1000-1911-2	FG1509	19.00	483	9.00

To Specify a DuraStar LED Illuminator on a RELIANCE® FG Series Water Gage Glass:

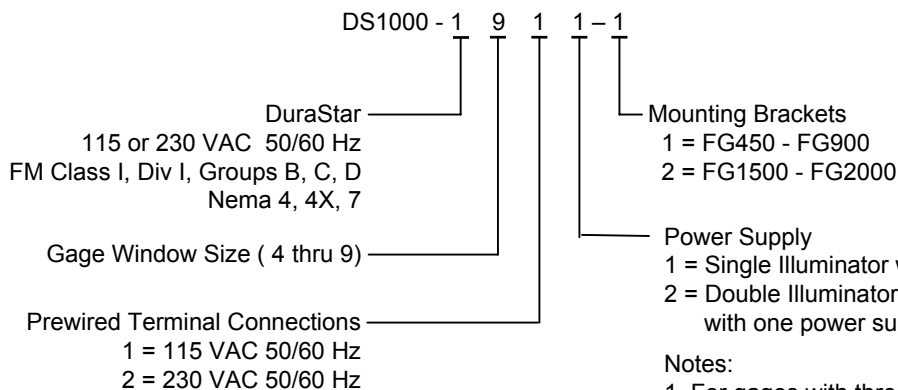

Notes:

1. For gages with three or more sections, combine single and double illuminators to minimize power supply requirements.
2. For remote mounting of power supply, specify Part No. V20602 for a 6.5' power cable extension.



16633 Foltz Pkwy., Strongsville, OH 44149 USA
 Telephone: (440) 572-1500 Fax: (440) 238-8828
 www.clark-reliance.com sales@clark-reliance.com

